



pulsar[®]

PRECISION

High-Tech Commercial Pool Disinfection with Powerful Performance







The Pulsar[®] Precision feeder is a high capacity erosion (HCE) feeder that is compact and lightweight with a modular design.

The feeder uses Pulsar[®] calcium hypochlorite briquettes that work in conjunction to produce a fresh concentrated liquid chlorine solution for clean and sanitized water. This innovative feeder system is easy to maintain and service with a flexible design that allows for easy integration for small to large commercial pools.







Switch to the Pulsar[®] Precision Feeder System, delivering clear and sparkling water time and time again!



Powerful Feeder Performance

-  Provides consistent chlorine delivery
-  Feeder designed to minimize maintenance requirements
-  2 in 1 dust reduction funnel for loading briquettes with capacity extension
-  Rotomolded components hold up to the strongest elements
-  Feeder design allows for easy access to internal components
-  Features high capacity erosion technology with the benefits of a venturi and booster pump

Briquette Efficiencies

-  Won't overstabilize pool
-  More concentrated than liquid bleach
-  Dry, easy to handle formulation
-  Will not cause reduction of ORP
-  Highly concentrated to reduce shipping and handling costs
-  Longer shelf life when compared to liquid bleach

A 3-in-1 product that chlorinates consistently, increases calcium to protect plaster and balances alkalinity to stabilize pH!

Pulsar[®] Precision Feeder System



PRECISION

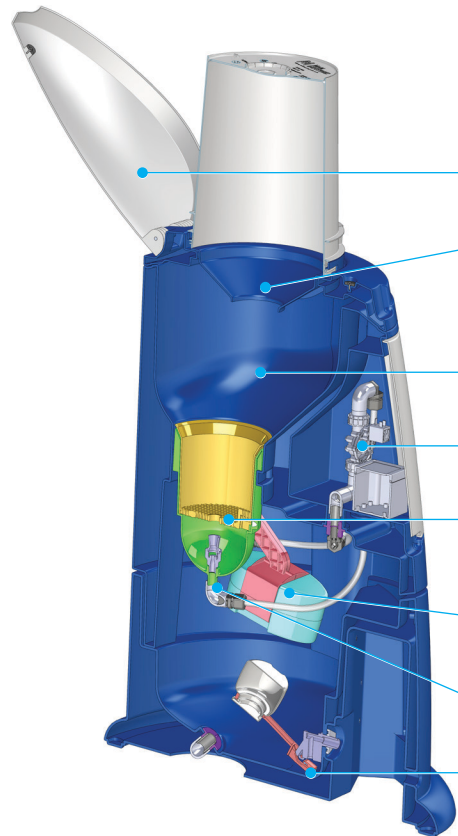

Secure lid locking feature

Enhanced hopper attachment

Allows for added chemical capacity and reduction in dust during chemical loading

Hopper

Dual solenoids minimize solid build up

Briquette grid

Removable for easy maintenance

Emergency shut-off valve to prevent spills

High capacity erosion nozzle

Durable discharge valve

Feeder Specifications

Width	25.3"	642.62mm
Depth	29.8"	756.92mm
Height	40.9"	1038.89mm
Water Inlet Size	1/2" MNPT	12mm MNPT
Solution Outlet Size	1/2" MNPT	12mm MNPT
Operating Weight	220lbs	99.7kg
Shipping Weight	60lbs	27.7kg
Dry Chemical Capacity	70lbs	31.75kg
Feed Rate Range	5-192lbs/day AvCl 0.2-8lbs/hour AvCl	2.3-87.3kg/day AvCl 0.09-3.6kg/hour AvCl
Electrical	115VAC	
Operating Temperature	40° - 120° F	4.4° - 48.9° C

Chemical Specifications

Active Ingredient	Calcium Hypochlorite	
Available Chlorine	68%	
Scale Inhibitor	0.4-1.0%	
Weight	7-10g	
Dimensions	1 1/4" x 3/4" x 1/2"	33mm x 19mm x 13mm
Chemical Form	Pillow shaped briquette	
Color	White	
Container	50lb pail	22.6kg pail

For more information visit www.pulsarsystems.net or call us at 1-800-4-PULSAR